



Torque Gauge Centor Star Touch Mini sensor



Advanced Torque Gauge

The manual Torque Gauge Centor Star Touch TM model is equipped with a miniature reaction torque sensor with 3/8 square end. Based on strain gauges technology is now the most advanced torque gauge. It allows you to easily and efficiently perform a wide variety of torque measurements on the field. Thanks to its male square you can adapt it to a large range of samples: screw, nuts, handle ... It is ideally suited to perform your small torque measurements.

The operators can collect in real time the graph of the torque vs time on the large color touch screen, without using a computer, and have a complete view of the current test. The torque gauge is also able to perform calculations on demand (minimum, maximum, break, average,...)

Optimized for industrial environment, it provides high-performance with a great ease of use, thanks to its large screen. The clear icon guides the user through the entire configuration in order to setup its test,

and menus are available in several languages. From the communication aspect, the Centor Star Touch has a bidirectional RS232 output able to send and receive data from a computer, an USB output at 1000hz able to send data in real time and as well as a switching output in order to optimize your process

Delivered with its certificate of calibration, including the measurement data in both directions, it is the most advanced instrument designed and built for the most demanding users.

Optimized for industrial environment, it is an ideal tool for tests during production.

Statistics

Statistics feature with automatic calculation of the average and standard deviation on 100 values in the memory.

MES / ECH	3
OPER	01
Unite	N
STATS	MXI
Nbech	002
Moy	12.33
001	12.334
001	12.332
001	12.331
002	12.335
002	12.334
002	12.330



Models and capacities

MODELS	CAPACITY	ACCURACY	RESOLUTION
CNR CT TM-04	0.4 Nm	0.002 Nm	0.04 mNm
CNR CT TM-07	0.7 Nm	0.0035 Nm	0.07 mNm

Specifications

FEATURES	CENTOR EASY TW	FEATURES	CENTOR EASY TW
Accuracy	0,5 % FS	Internal memory	1000 results, 1 curve
Resolution	1/10,000 FS	Reversible display	90° and 180°
Data acquisition rate	1,000 Hz	Operates on rechargeable batteries	√
Overload protection	200% FS	8 hours of operation without recharging	√
Units	Nm, kgcm, mNm, lbin	Fast charge	√
Auto-off	Adjustable from 5 to 15 min	Low battery indicator	√
Bargraph	√	Metal casing and protective over mould	√
Clockwise and counterclockwise peak	√	RS232 output	Current value, min or max
Simultaneous display of peak and current reading	√	Data rate RS232	100 values per second
Display of the Torque/Time graph	√	Data rate USB	1000 values per second
Use of a Foot pedal	√	Analogic output	+/- 1V
Tare function	√	Backlit display	√
Programmable set point	√		
Statistics	√		

Torque Gauge Centor Star Touch Mini sensor



Measure screen

Usability

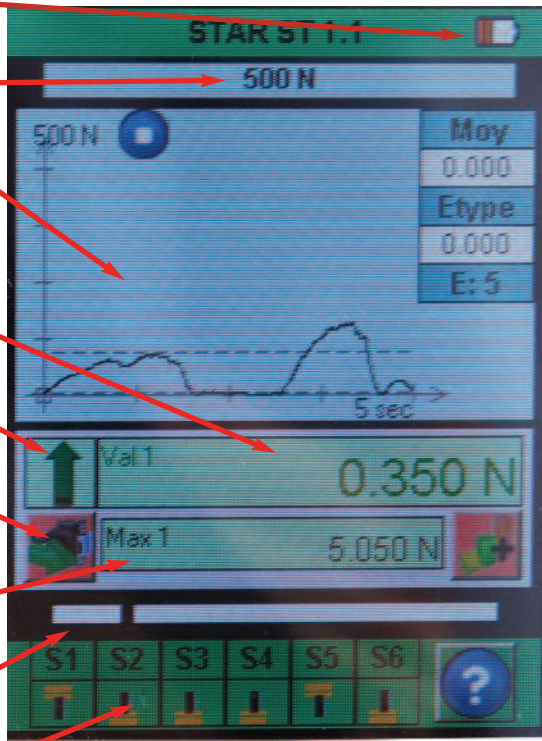

Battery indicator

Force gauge maximum capacity

Graph displayed gauge vs time

Main display programmable

Measurement direction

Sending data through RS232

Secondary display programmable

Analog load bar with set point marker

TTL output status



EASY : Menu

- Affichage
- ESSAI
- Statistiques
- Communication
- Général
- Maintenance

temps d'attente avant bascule de luminosité: 30 sec

7 8 9

4 5 6

1 2 3

0

The Centor Star Touch has simple and user-friendly menus, thanks to its large color screen. The setting of the force gauge and the test configurations are done using the touch screen: keyboard, down menu, icons

Options - Software

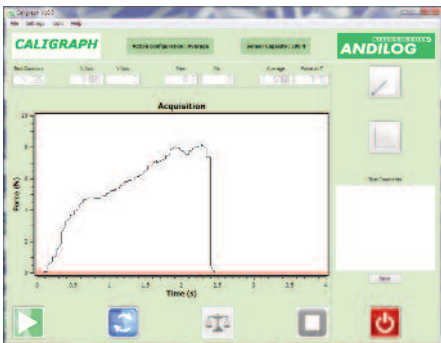

CALIGRAPH

Acquisition

Compatible with CALIGRAPH software: curve acquisition and reporting software for computer. Connects your Centor to CALIGRAPH to achieve in real time the acquisition of your measurements and allow recording of your values on your computer.

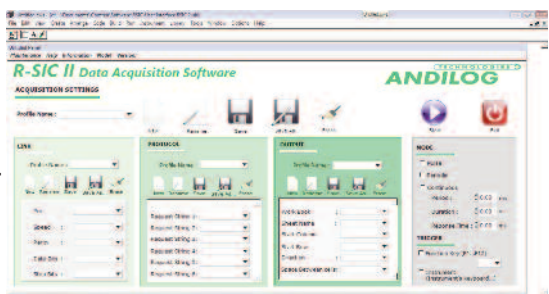

R-SIC II Data Acquisition Software

ACQUISITION SETTINGS

Profile Name:

MODE:

Compatible with RSIC software: saves your data on an Excel sheet directly through RS232. Allow real time communication as well as unloading the calculation values recorded in the Centor.



Torque Gauge Centor Star Touch Mini sensor



Dimensions

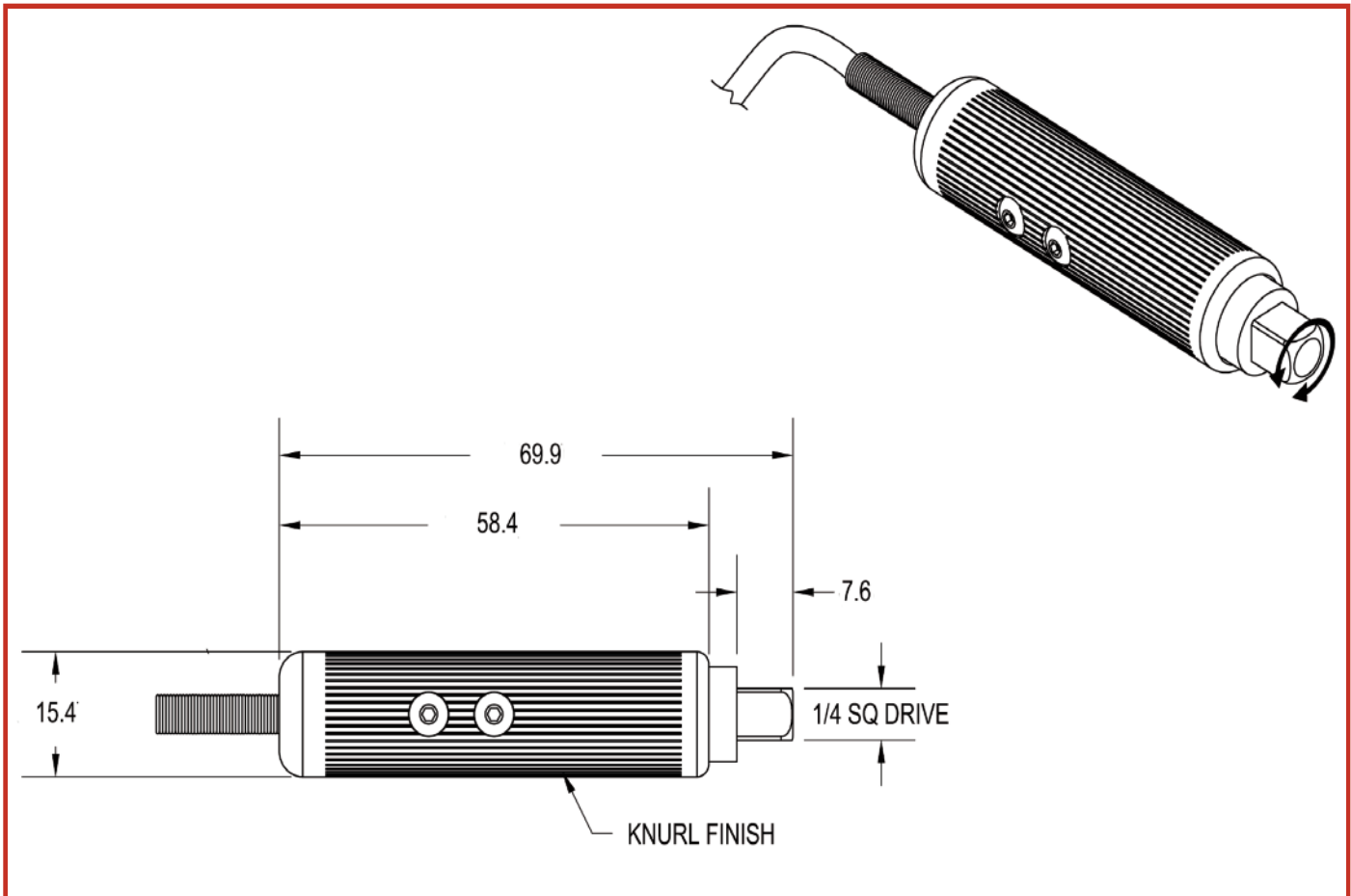

Options - sensors

Housing dimensions

In option, we have a large variety of sensors in order to comply with your dimensions and applications. Feel free to contact us.

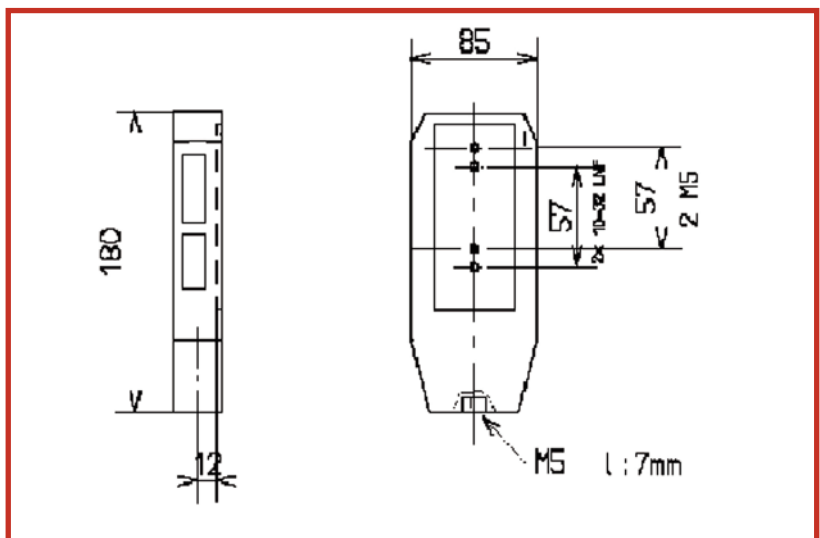
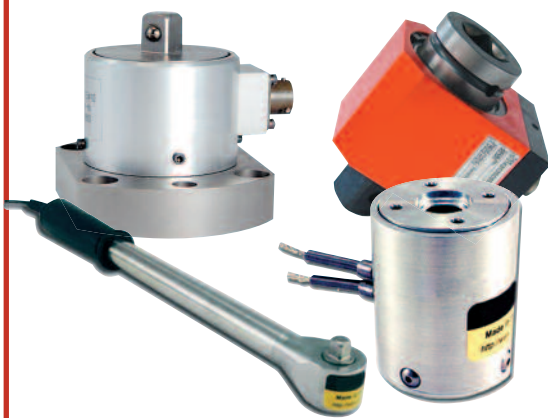

ISO 9001:2008 certified

ANDILOG Technologies

BP 62001

13845 Vitrolles Cedex 9, FRANCE

info@andilog.com • www.andilog.com

Phone : +33 (0) 820 888 202 • Fax : +33 (0) 820 888 902